

# BRISTAN

TAPS & SHOWERS

## Installation Instructions & User Guide

Please leave these instructions with the end user

Product Code: GLL FLEXSNK C (D1)

### Specifications

#### Dynamic Water Pressure

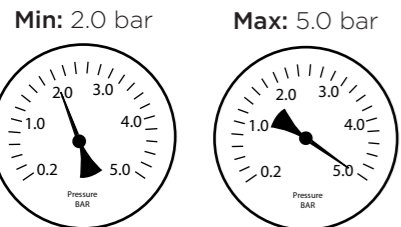

Maximum Static Pressure: 10.0 bar

#### Inlet Water Temperature

##### Cold Water Supply

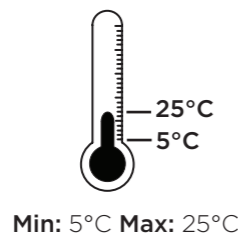

Min: 5°C Max: 25°C

##### Hot Water Supply

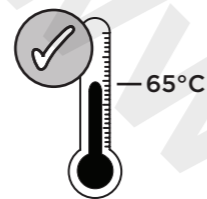

65°C Recommended

#### Inlet Connections



Marked red for hot

1/2" BSP Flexible Tails

### Tools You'll Need



Adjustable Spanner Pipe Cutter Hexagonal Key

### Servicing Your Tap

We recommend servicing your tap at least once every year to prolong its life. To see a video showing how to remove the cartridge for servicing, scan the QR code with your smart phone or tablet.



Alternatively visit [www.bristan.com/howto](http://www.bristan.com/howto)

### Prior to Installation

All products manufactured and supplied by Bristan are safe provided they are installed, used correctly and receive regular maintenance in accordance with these instructions.

This product has been tested to the Water Regulations Advisory Scheme (WRAS) and satisfies the requirements of the Water Supply (Water Fittings) Regulations 1999 and current bylaws. For full Installation Requirements & Notes (IRN) please visit [wras.co.uk/directory](http://wras.co.uk/directory).

Isolation valves must be fitted to the inlet water supplies to ensure ease of future maintenance.

Before installing these taps the water supply must be thoroughly flushed in order to remove any swarf, solder etc.

This product must not be modified in any way as this will invalidate the guarantee.

### Flexible Connecting Pipes

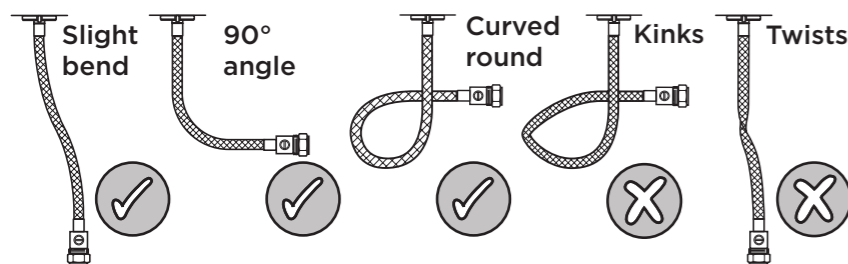

### Pack Contents

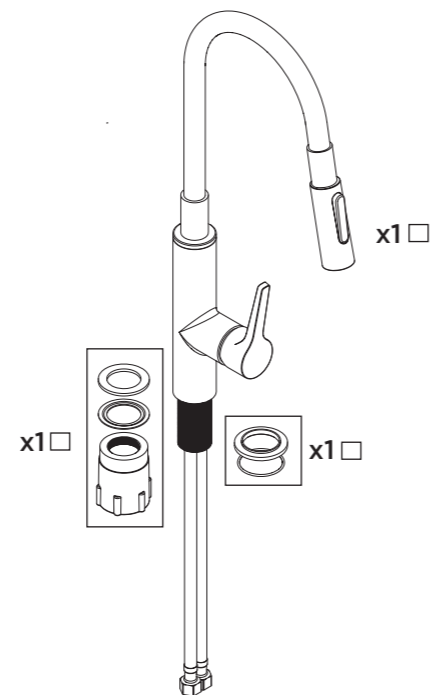

### Spare Parts

To replace any spare parts for your tap, why not scan the QR Code or visit [www.bristan.com](http://www.bristan.com) and search for your product.



### Installation

1

Put the plinth over the top of the sink hole, ensuring the O-Ring, is underneath

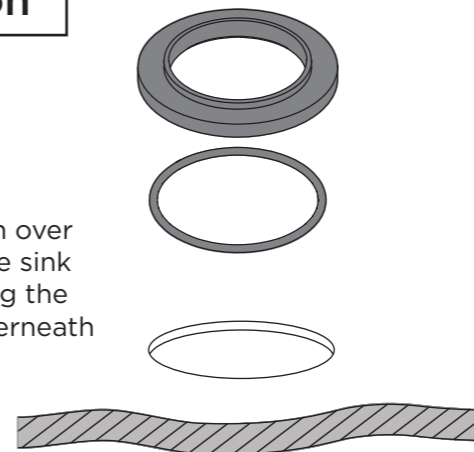

4

Connect the hot and cold water connections.



IMPORTANT fit isolation valves for future maintenance

Olive

Compression Nut

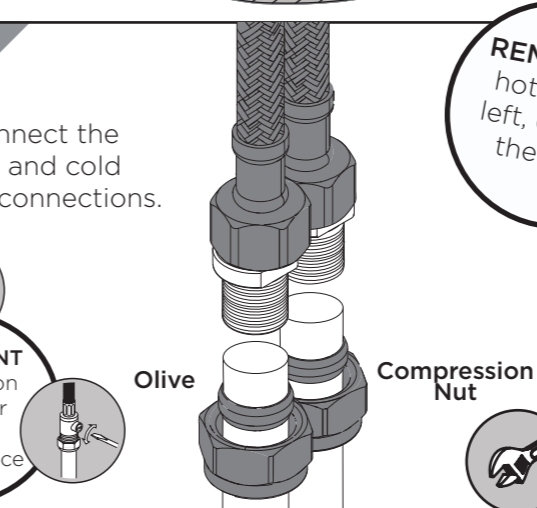

REMEMBER hot on the left, cold on the right

2

Feed the pipes through the sink hole and place the tap body.

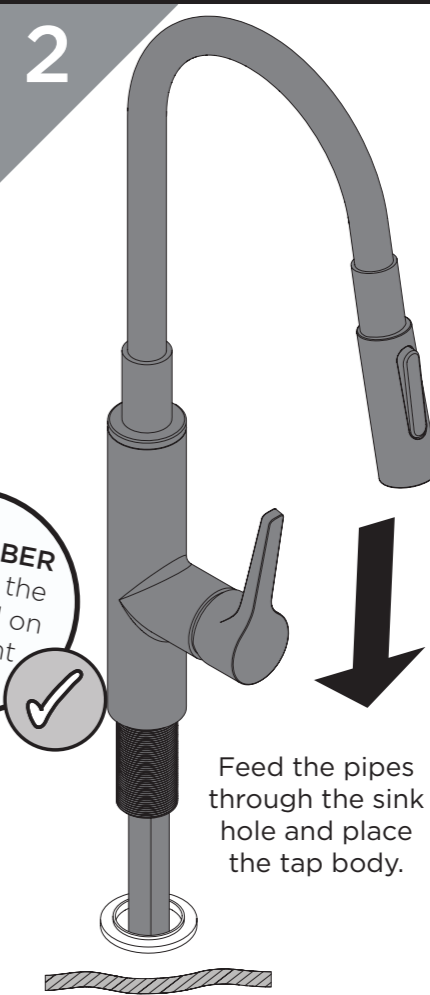

3

Push the washers against the tap body and tighten with the fixing nut.

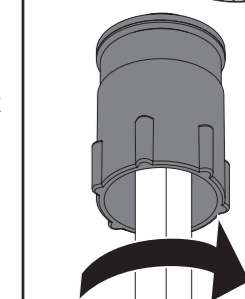

5

Switch on the water supply and check connections for any leaks.

Your tap is now ready to use.

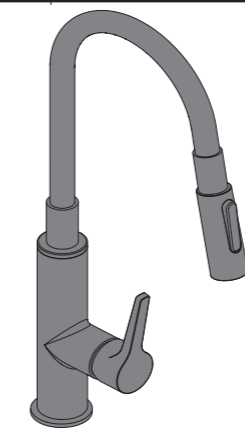

### Operation

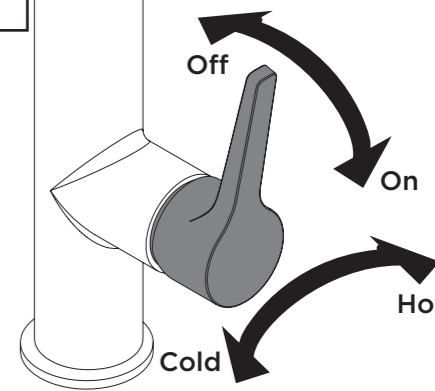

### Spout Features

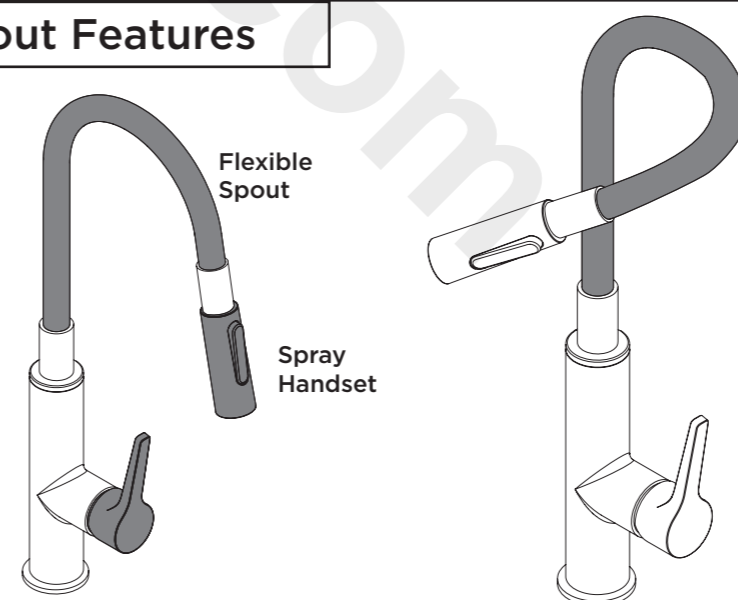

### Continuous Flow

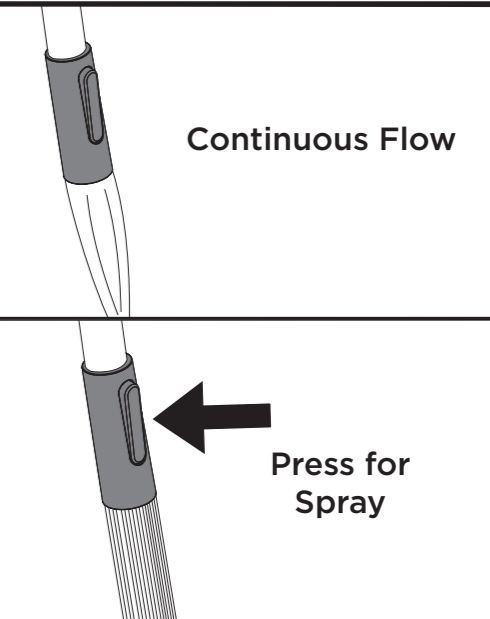

## General Cleaning

Your fitting has a high quality finish and should be treated with care to preserve the visible surfaces.

All surfaces will wear if not cleaned correctly, the only safe way to clean your mixer tap is to wipe with a soft damp cloth. Stains can be removed using washing up liquid. All bath cleaning powders and liquids will damage the surface of your fitting, even the non-scratch cleaners.

**Note:** Never use abrasive detergents or disinfectants or those containing alcohol, hydrochloric acid or phosphoric acid.

## Maintenance - Cleaning/Replacing Cartridge

**1** Remove cap. Undo grub screw and remove handle.

**2** Using a suitable tool, remove shroud and retaining nut. Remove cartridge.

**3** Place cartridge in a suitable solution and soak until fully descaled.

**4** Replace cartridge. Screw on retaining nut and shroud.

**5** Replace handle. Tighten the grub screw and replace the cap.

**6** Turn on the mains water supply, letting the water flow for a few minutes to flush through the system.

**IMPORTANT** Isolate the water supply before starting!

2.5 mm

2.5 mm

## Troubleshooting

Symptom	Cause(s)	Remedy
No flow or low flow rate	Partially closed isolation valve.	Open isolation valve.
	Instantaneous water heater cycles on and off as flow rate or pressure is too low.	Increase water flow rate or pressure through system.
	Head of water is below the minimum distance required.	Check the site has the required working pressures according to the specification.
	Hot or cold water being drawn off elsewhere causing pressure changes or instantaneous boiler temperature changes.	Do not use other water outlets when using the taps.
	Airlock or partial blockage in the supply pipework or hoses.	Flush through pipework to ensure removal of debris and any airlocks.
	Water supply failure	Investigate water supply. Check your plumbing and heating systems for any faults.
	Hose is leaking due to aging/damaged O-Rings or Anti-Friction seals	Call Customer Services for replacement seals
Water dripping from taps	This is normal for a short time after using the taps.	This is caused by residual water tension, the build up of water in the tap body.
	If water continues to drip, possibly due to the ceramic disc valves/cartridge	Remove valves/cartridge and clean, refer to 'Maintenance' section before starting any maintenance.
Taps do not turn on	Closed isolation valve.	Open isolation valve.
	Mains water supply turned off.	Turn on mains water supply.
Handset Pressure Changes	Site water pressure is too high for the working pressures listed on the specification.	Install a Pressure Reducing Valve in order to achieve working levels of pressure.

## Notes

Please use this space for any notes you or your installer may have regarding the installation/plumbing of this product.

At Bristan, we want to make things as easy as possible for our customers. That's why we offer solid guarantees on all our products, effective from the date of purchase, to give you peace of mind.

To start your free guarantee simply scan the QR code and register your product. Alternatively visit [www.bristan.com/register](http://www.bristan.com/register).

For any other queries, please call our Customer Service on 0330 026 6273 where our expert team of advisors will be able to offer you any help and advice.

For full guarantee terms and conditions visit [www.bristan.com/guarantees](http://www.bristan.com/guarantees).



*We Know & We Care*